

## GFJ7145TC Power Schottky Module Bypass Diode

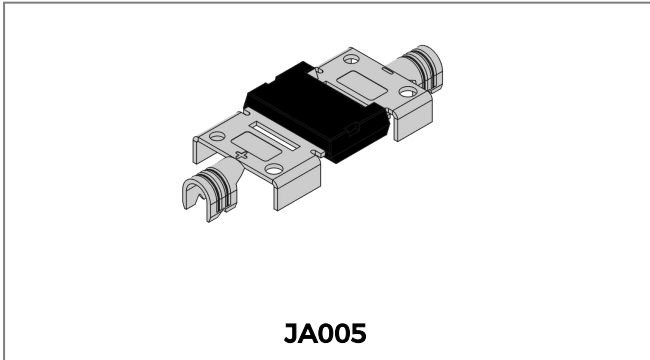

### Features

- Low thermal resistance
- Lower forward voltage drop, low power loss
- Isolate Package design, ideal for heat dispersion
- High forward current capability
- Trench MOS Schottky technology
- Excellent anti-humidity
- Low profile package
- High forward surge capability
- All SMC parts are traceable to the wafer lot
- Additional electrical and life testing can be performed upon request

### Mechanical Data

- Case: JA005
- Terminals: Copper
- High temperature soldering guaranteed
- Heated-tool welding 260°C, 10seconds
- Marking Code: GFJ7145TC

### Maximum Ratings(limiting values, at 25 °C unless otherwise specified)

Characteristics	Symbol	Condition	Max.	Units
Peak Repetitive Reverse Voltage Working Peak Reverse Voltage DC Blocking Voltage	$V_{RRM}$ $V_{RWM}$ $V_R$	-	45	V
Average Rectified Forward Current	$I_{F(AV)}$	$T_C=95^\circ\text{C}$ , In DC	70	A
Peak One Cycle Non-Repetitive Surge Current	$I_{FSM}$	8.3 ms, half Sine pulse	450	A

### Electrical Characteristics:

Characteristics	Symbol	Condition	Typ.	Max.	Units
Forward Voltage Drop*	$V_{F1}$	@ 70A, Pulse, $T_J = 25^\circ\text{C}$	0.47	0.52	V
Reverse Current*	$I_{R1}$	@ $V_R = \text{rated } V_R$ , $T_J = 25^\circ\text{C}$	0.04	0.20	mA
	$I_{R2}$	@ $V_R = \text{rated } V_R$ , $T_J = 100^\circ\text{C}$	-	60	mA
	$I_{R3}$	@ $V_R = \text{rated } V_R$ , $T_J = 125^\circ\text{C}$	-	120	mA
Junction Capacitance	$C_T$	@ $V_R = 5\text{V}$ , $T_C = 25^\circ\text{C}$ $f_{SIG} = 1\text{MHz}$	8776	-	pF

\* Pulse width < 300  $\mu\text{s}$ , duty cycle < 2%

**Thermal-Mechanical Specifications:**

Characteristics	Symbol	Condition	Specification	Units
Junction Temperature	$T_J$	IN DC Forward Mode, without reverse bias, $t \leq 1$ h	-55 to +200	$^{\circ}\text{C}$
Storage Temperature	$T_{\text{stg}}$	-	-55 to +150	$^{\circ}\text{C}$
Typical Thermal Resistance Junction to Case	$R_{\theta\text{JC}}$	-	1	$^{\circ}\text{C}/\text{W}$

**Ratings and Characteristics Curves**

Figure 1 Typical Forward Characteristics

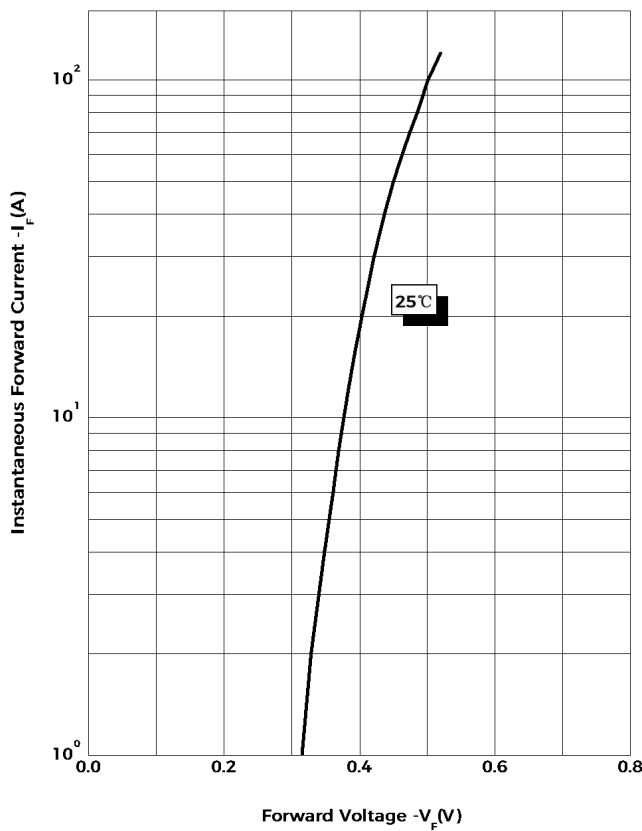

Figure 2 Typical Reverse Characteristics

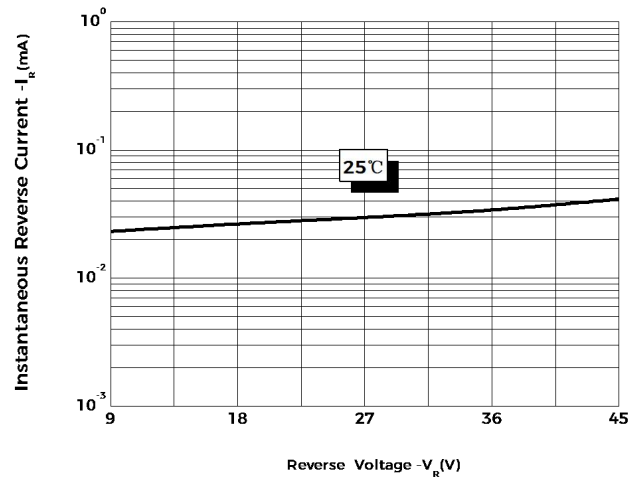
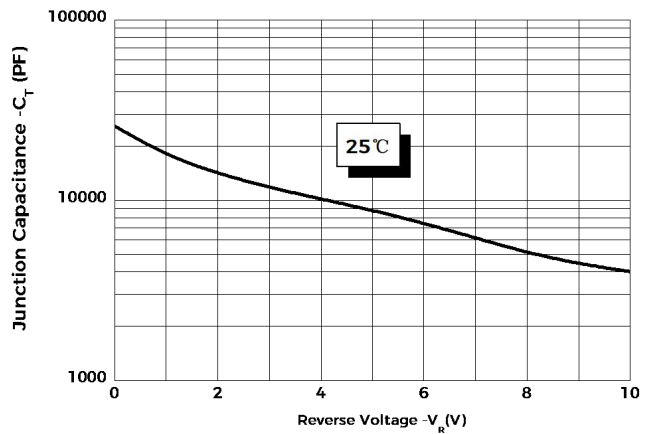

Figure 3 Typical Junction Capacitance



Technical Data  
Data Sheet N3193, Rev.-

**Ordering Information**

Device	Package	Shipping
GFJ7145TC	JA005	30pcs/Tube

**Marking Diagram**

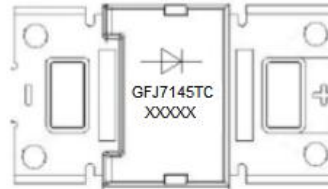

Where XXXXX is YYWWL

GFJ7145TC = Device Code  
YY = Year  
WW = Week

Order P/N	Terminals	Additional
GFJ7145TC-S1	Tin Plated	None
GFJ7145TC-S3	Tin Plated	Solder Block



Solder Block

**Solder block Specification**

The composition of the tin block is Sn50Pb50 with flux.  
The size of the tin block is  $6(\pm 0.15) \times 3.5(\pm 0.15) \times 1(\pm 0.08)$  mm.  
The composition and size of tin blocks can be customized according to customer requirements.  
Solder block to be centered, not exceed the flat groove.

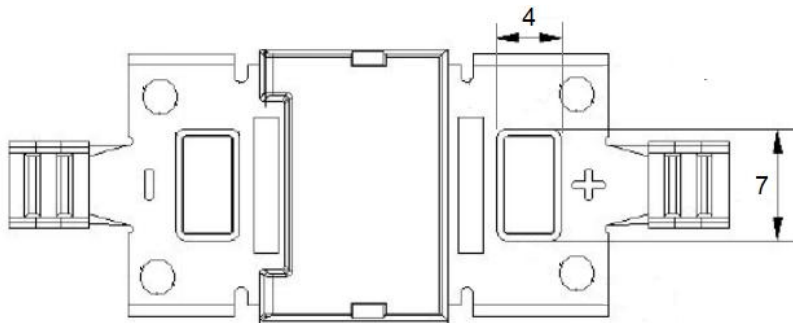

**Mechanical Dimensions JA005 (Millimeters)**

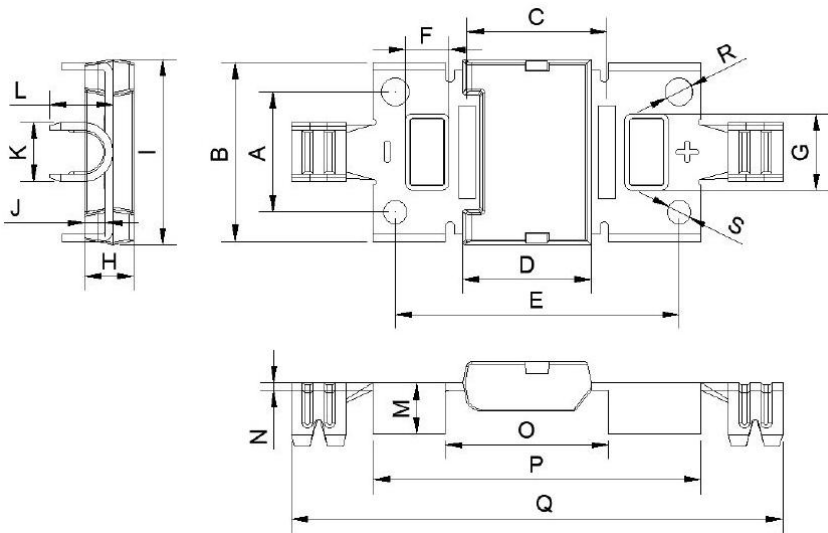

Symbol	Dimensions in millimeters	
	Min.	Max
A	10.5	11.5
B	15.9	16.9
C	12.6	13
D	11.23	12.23
E	25.5	26.5
F	3.5	4.5
G	6.5	7.5
H	4.3	4.7
I	16.5	17.5
J	1.7	2.1
K	5	5.8
L	5.6	6
M	4.4	5
N	0.6	0.8
O	14.73	15.13
P	29.5	30.5
Q	44.5	45.5
R	2.35	2.65
S	2	2.3

**Technical Data**  
**Data Sheet N3193, Rev.-**

**DISCLAIMER:**

- 1- The information given herein, including the specifications and dimensions, is subject to change without prior notice to improve product characteristics. Before ordering, purchasers are advised to contact the SMC Diode Solutions sales department for the latest version of the datasheet(s).
- 2- In cases where extremely high reliability is required (such as use in nuclear power control, aerospace and aviation, traffic equipment, medical equipment , and safety equipment) , safety should be ensured by using semiconductor devices that feature assured safety or by means of users' fail-safe precautions or other arrangement .
- 3- In no event shall SMC Diode Solutions be liable for any damages that may result from an accident or any other cause during operation of the user's units according to the datasheet(s). SMC Diode Solution assumes no responsibility for any intellectual property claims or any other problems that may result from applications of information, products or circuits described in the datasheets.
- 4- In no event shall SMC Diode Solutions be liable for any failure in a semiconductor device or any secondary damage resulting from use at a value exceeding the absolute maximum rating.
- 5- No license is granted by the datasheet(s) under any patents or other rights of any third party or SMC Diode Solutions.
- 6- The datasheet(s) may not be reproduced or duplicated, in any form, in whole or part, without the expressed written permission of SMC Diode Solutions.
- 7- The products (technologies) described in the datasheet(s) are not to be provided to any party whose purpose in their application will hinder maintenance of international peace and safety nor are they to be applied to that purpose by their direct purchasers or any third party. When exporting these products (technologies), the necessary procedures are to be taken in accordance with related laws and regulations..